

JIBBI

PATENT PENDING

1250 EVO



ALMACRAWLER

JIBBI 1250 EVO

JIBBI è la nuova piattaforma area semovente telescopica cingolata di AlmaCrawler.

JIBBI is the new crawler telescopic boom by AlmaCrawler.

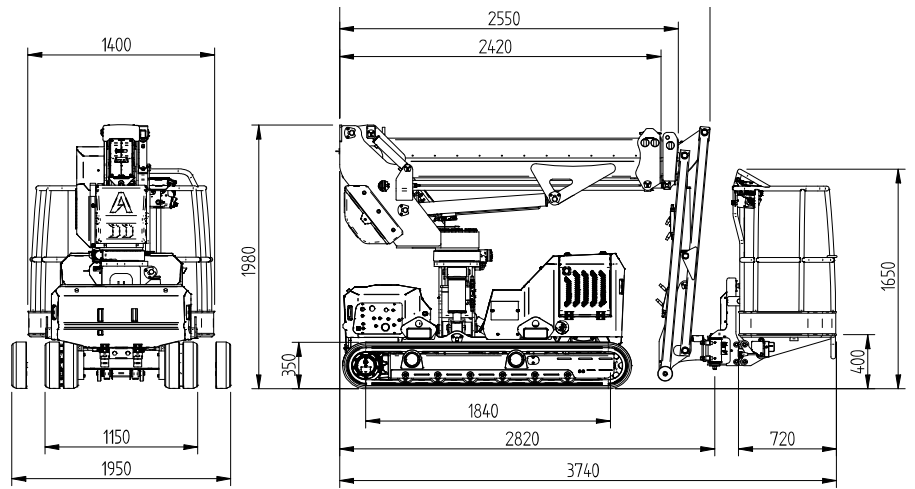

Brevetti in approvazione

Nuovo Dynamic Work Performance (DWP by Almac)

Sottocarro integrato con nuovo Safe-lock System

Patent pending innovations

New Dynamic Work Performance (DWP by Almac)

Undercarriage integrated by new Safe-lock System



Console via cavo by AUTEK
Cable remote console by AUTEK

Caratteristiche Features

- Motore Diesel Yanmar, 3 cilindri (14,1kW - 19,2 HP)
- Rotazione ralla 240°
- Rotazione navicella +/- 70°
- Integrated Drive System (guida a singolo joystick)
- Yanmar Diesel Engine, 3 Cylinders (14,1kW - 19,2 HP)
- 240° Slewing ring rotation
- Basket rotation kit +/- 70°
- Integrated Drive System (using single joystick)

Sistema anticollisione bidirezionale ad ultrasuoni

Ultrasonic Anti-collision System



Livellamento

contemporaneo su due assi

Automatic & Dynamic Levelling